

CROSS-BELT SORTER – A MODEL AND ANALYSIS OF SELECTED MECHANICAL LOADS

Tomasz Piatkowski ¹ 

¹UTP University of Science and Technology, Faculty of Mechanical Engineering, Kaliskiego 7, 85-796 Bydgoszcz, Poland, email: topiat@utp.edu.pl, <https://orcid.org/0000-0002-8000-7813>

Reviewed positively: 07.02.2021

Information about quoting an article:

Piatkowski T. (2020). Cross-belt sorter – a model and analysis of selected mechanical loads. Journal of civil engineering and transport. 2(3), 139-148, ISSN 2658-1698, e-ISSN 2658-2120, DOI: [10.24136/tren.2020.011](https://doi.org/10.24136/tren.2020.011)

Abstract – This article presents the results of numerical research on operational mechanical loads, carried out for the main structural elements of a cross-belt sorter: tracks and trolleys with trays. The goal of the research was to collect data required at the stage of designing new solutions of the sorters. A novelty is an analytical model that allows to determine the influence of the motion velocity of trolleys, frictional properties and mass of sorted objects on the forces transmitted from the trolleys to the track, the sorting efficiency and power required by the drive systems.

Key words – sorting process, tray, trolley, unit load, logistic center

JEL Classification – R40, L91

INTRODUCTION

The problem of sorting unit products emerges wherever we have high concentration of them. It is accompanied by the tasks of picking and unpicking of deliveries of unit loads in the logistic distribution centres, for example, in the junction post offices, logistic centres of courier companies, online trade centres selling goods by mail order. The objects are divided into particular directions as intended with the use of non-grab manipulators integrated into conveyor transport system, affecting the objects by properly planned push, hit or sequence of pushes [1-4]. An example of a system of lines of automatic sorting of loads was shown on Fig. 1.

The practical representation of an idea of the process of non-grab manipulating of the objects is

a sorting system of cross-belt type, equipped with the trays covered with transverse conveyors (Fig. 1, Fig. 2). This system is characterized by high efficiency and mild dynamic influence exerted on redirected objects.

The change of direction of transporting results only from frictional contact of the objects with the belt of a conveyor of a tray, built in the trolleys directed in the track making a closed loop.

For optimal use of existing solutions and designing new sorting systems, we need data (technical recommendations) resulting from the nature of the course of the manipulating process and physical properties of transferred objects. However, these data cannot be found in contemporary literature.

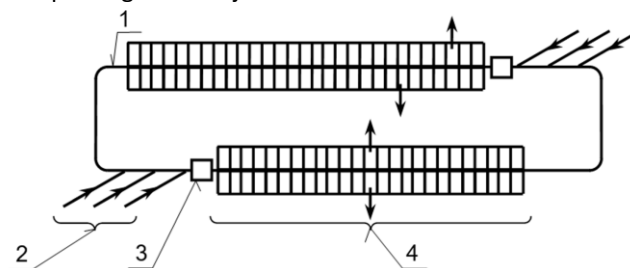

Fig. 1. Line of automatic sorting of unit loads [5-6]: 1 – a track with the trays, 2 – infeed lines, 3 – identification (scanner of codes, mass and linear dimensions), 4 – outfeed lines



Fig. 2. Trays with transverse conveyors, placed on the trolleys directed in a track (enlargement of a detail from Fig. 1) [5]

The companies producing complete systems of warehouse automation publish trade offers without significant technical data and correlations resulting from them. Therefore, it is necessary to carry out own research, on the basis of law of physics.

The results of calculations of mechanical reactions occurring between transported object, surface of a tray, driving elements of a trolley and main track of a sorter were presented in the article. The research was carried out in a relation of basic operational and structural parameters: radius of the arcs of the tracks, velocity of transporting goods and their frictional properties.¹

It takes the load resulting from putting trolleys, trays and transported products on it. The most loaded structural elements of the track are arcs that are affected, apart from gravitational forces, by centrifugal forces. Due to the requirement of the lack of tendency to overturning the trolleys in motion on the bends and prevention of falling the objects down from the trays, inclination of arcs of the tracks by the angle α towards the horizontal was considered (Fig. 3, Fig. 12).

During the research, we included the parameters, specified on the basis of an analysis of solutions of the sorters available in the offer materials of the suppliers of sorting systems [5-6] and adopted in a project executed within the National Centre for Research and Development grant [3]. Selected parameters are presented in Table 1.

1. MODEL AND ANALYSIS OF MOTION OF THE TROLLEYS IN A TRACK

Track is the main load-bearing element of a sorter.

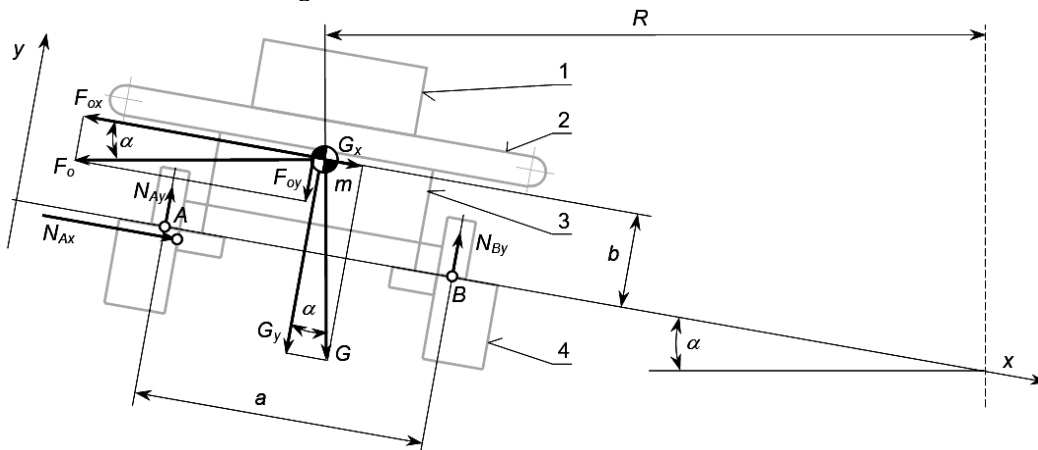

Fig. 3. A diagram of forces exerted on a trolley moving on the arc of the track inclined towards the horizontal at an angle α : 1 – object, 2 – tray, 3 – trolley, 4 – track

¹ Article was created as part of the project NCBR POIR.04.01.04-00-0006/19. „Cross-belt system for automated sorting of unit loads by a two-stage method”

Table 1. Structural parameters of a trolley

Marking	Quantity	Value
m	mass of a trolley	45 kg
m _p	mass of a transported object	25 kg
a	distance between internal surfaces of the tracks	0.590 m
b	position of the centre of gravity of mass of a trolley and object above the surface of the tracks	0.202 m
v	maximum velocity of motion of the trolleys	2.5 m/s
R	radius of the track bend	2.5 m

THE ISSUE OF OVERTURNING A TROLLEY ON THE ARC OF A TRACK

Permissible velocity v (Fig. 13) of motion of a trolley, moving on the arc of the track inclined towards the horizontal at an angle α , was determined on the basis of a diagram of forces shown on Fig. 3. These forces are analysed in a rectangular coordinate system xy , with x axis connected with bearing surface of the track, placed along radius of the arc. During the research, the impact of force of transportation and Coriolis force was omitted. It was assumed that initiation of overturning a trolley outside of the arc towards point A occurs when reaction force in the point of contact B is fading, that is, $N_{By} = 0$. The condition of not overturning a trolley is presented by an equation:

$$F_{ox}b \leq 0.5F_{oy}a + G_xb + 0.5G_ya \quad (1)$$

where:

F_o, F_{ox}, F_{oy} – centrifugal force and its components:

$$F_o = \frac{mv^2}{R}, F_{ox} = F_o \cos \alpha, F_{oy} = F_o \sin \alpha \quad (2)$$

G, G_x, G_y – force of gravity and its components:

$$G = mg, G_x = G \sin \alpha, G_y = G \cos \alpha \quad (3)$$

g – gravitational acceleration.

Permissible velocity determined based on the equation (1) is:

$$v \leq \sqrt{\frac{gR(b \sin \alpha + 0.5a \cos \alpha)}{b \cos \alpha + 0.5a \sin \alpha}} \quad (4)$$

$$\sum M_{iA} = F_{ox}b - 0.5F_{oy}a - G_xb - 0.5G_ya + N_{By}a = 0 \quad (5)$$

$$\sum F_{ix} = N_{Ax} - F_{ox} + G_x = 0 \quad (6)$$

$$\sum F_{iy} = N_{Ay} + N_{By} - F_{oy} - G_y = 0 \quad (7)$$

The components of reaction forces in the points of contact A and B are:

$$N_{By} = \frac{-mv^2(b \cos \alpha - 0.5a \sin \alpha) + Rmg(b \sin \alpha + 0.5a \cos \alpha)}{aR} \quad (8)$$

Fig. 4 shows a graph of permissible velocity of a trolley in a function of angle α of inclination of a track and radius of the bend R . An analysis of the graph shows that in case of application of velocity of motion of the trolleys $v = 2.5$ m/s and radius of the bend $R = 2.5$ m (frequently adopted in high-efficiency warehouse transport systems), there is no need to apply inclinations of the tracks. With application of the arc of radius $R = 2.5$ m, permissible velocity for $\alpha = 0^\circ$, due to requirement of not overturning the trolleys is about $v = 6$ m/s, that is, velocity is more than two times higher than maximum velocities applied in the warehouses.

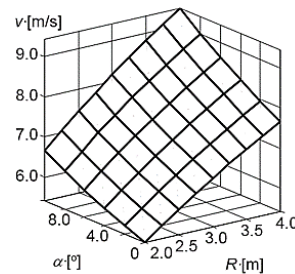

Fig. 4. Permissible velocity of motion of a trolley due to overturning on the arc of the track in a function of radius R and angle of inclination α

THE FORCES OF IMPACT OF A TROLLEY ON A TRACK

A diagram from Fig. 3 was also used to determine the forces of pressure of a trolley on the tracks in the points of contact A and B.

The conditions of static balance of a trolley are defined by the equations:

Cross-belt sorter – a model and analysis of selected mechanical loads

$$N_{Ay} = -N_{By} + F_{oy} + G_y \quad (9)$$

$$N_{Ax} = F_{ox} - G_x \quad (10)$$

The forces of pressure of a trolley on the tracks were shown on Fig. 5-9. Fig. 5, Fig. 6 and Fig. 8 refer to the tracks placed horizontally ($\alpha = 0^\circ$), and Fig. 7 and Fig. 9 – inclined at an angle of $\alpha = 10^\circ$.

Fig. 5 shows no danger of overturning a trolley –

$N_{By} > 0$. In case of application of the tracks placed horizontally ($\alpha = 0^\circ$, Fig. 5, Fig. 6 and Fig. 8) and velocity of motion of trolleys $v = 2.5$ m/s, external track is much more loaded than internal one: for $R = 2.5$ m, $N_{Ay} = 380$ N, $N_{Ax} = 170$ N and $N_{By} = 270$ N. The application of inclination of the tracks ($\alpha = 10^\circ$, Fig. 7 and Fig. 9) contributes to more uniform distribution of load: for $R = 2.5$ m, $N_{Ay} = 350$ N, $N_{Ax} = 50$ N and $N_{By} = 320$ N.

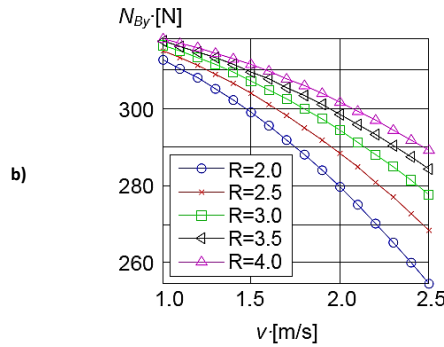
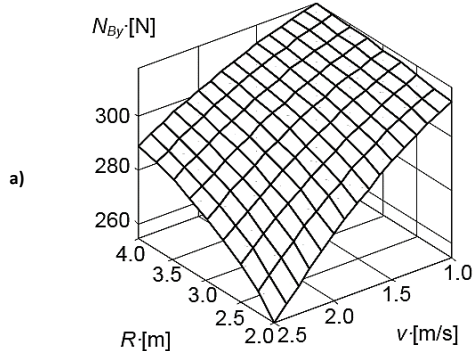

Fig. 5. The component of reaction force N_{By} of a trolley: a) in R and v function, b) in v function; $\alpha = 0^\circ$, $m = 45$ kg, $m_p = 25$ kg

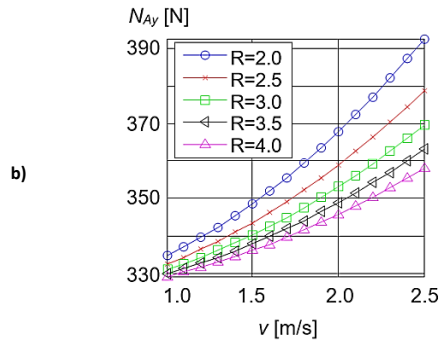
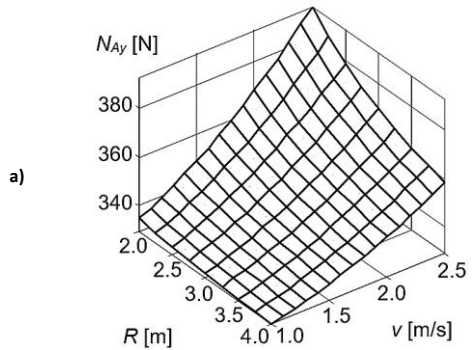

Fig. 6. The component of reaction force N_{Ay} of a trolley: a) in R and v function, b) in v function; $\alpha = 0^\circ$, $m = 45$ kg, $m_p = 25$ kg

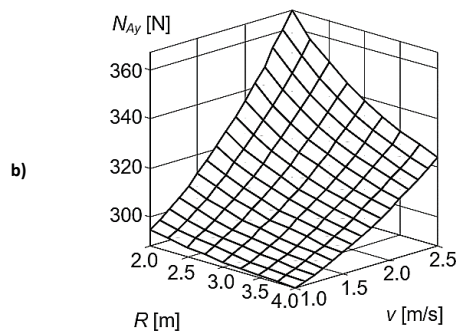
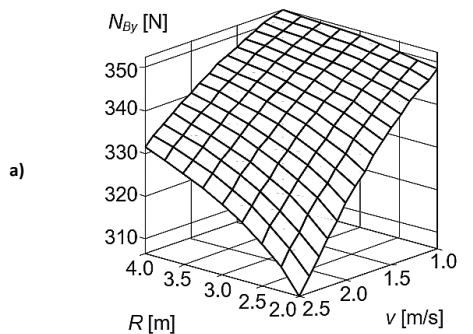

Fig. 7. Load of the tracks towards axis y: a) component N_{By} , b) component N_{Ay} ; $\alpha = 10^\circ$, $m = 45$ kg, $m_p = 25$ kg

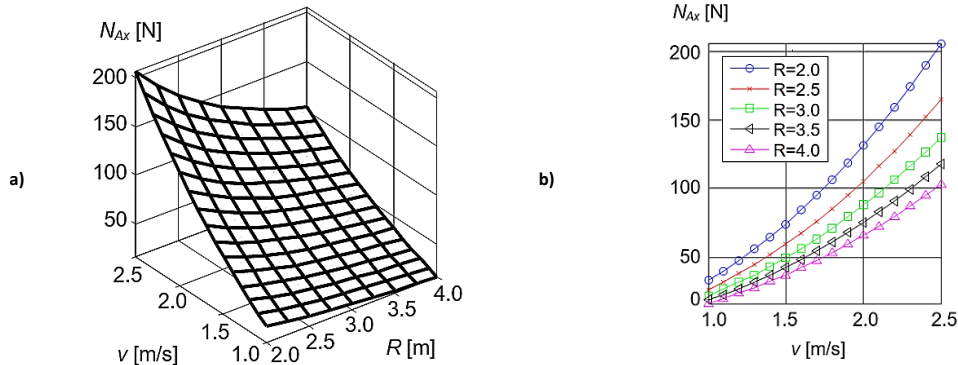

Fig. 8. The component of reaction force N_{Ax} of a trolley: a) in R and v function, b) in v function; $\alpha = 0^\circ$, $m = 45$ kg, $m_p = 25$ kg

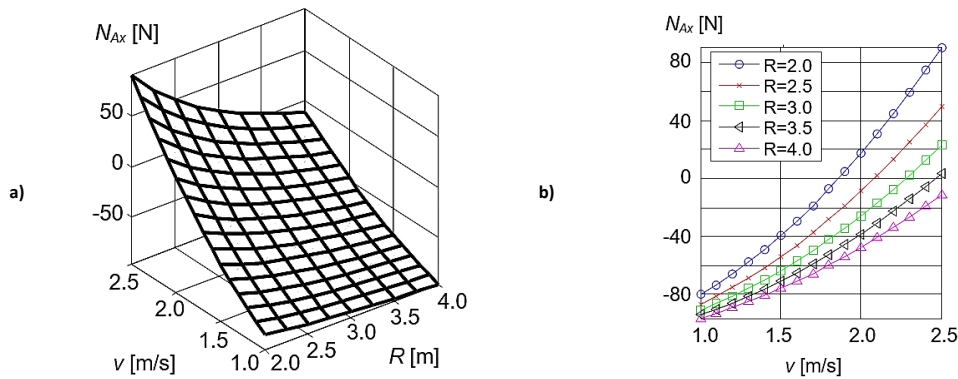

Fig. 9. The component of reaction force N_{Ax} of a trolley: a) in R and v function, b) in v function; $\alpha = 10^\circ$, $m = 45$ kg, $m_p = 25$ kg

THE ISSUE OF FALLING OF TRANSPORTED OBJECTS ON THE BENDS

Centrifugal force affecting transported objects on the bends may cause unintentional slipping off objects from the trays. Therefore, analytical model has been developed that allows to determine required frictional properties of an object in the context of velocity of transporting, radius of the curvature of the bend and angle of inclination of the track. In this model, a diagram from Fig. 12 was used. It was assumed that frictional properties are described in accordance with Coulomb model that belongs to the class of the so-called static models [6-10]. In these models, friction force is a static mapping of coefficient characteristics. They are less complex than dynamic models [11-17] that allow to recreate hysteresis effects occurring during low velocity of skid, for example, pre-sliding hysteresis, frictional lag, break-away force. Coulomb model in discussed application is sufficient because carried

out analyses refer only to existence of the state of static friction. Skid is not considered because it would lead to the loss of control of transported object and to faulty work of a sorting system.

The condition of not slipping of an object from the trays outside of the bend is expressed by an inequality:

$$T + G_x \geq F_{ox} \tag{11}$$

where:

T – friction force:

$$T = \mu(G_y + F_{oy}) \tag{12}$$

hence:

$$\mu \geq \left| \frac{v^2 \cos \alpha - Rg \sin \alpha}{v^2 \sin \alpha + Rg \cos \alpha} \right| \tag{13}$$

Expected values of frictional properties of a tray, protecting an object against unintentional fall during its motion on the curvatures of the track of the main conveyor, were shown on Fig. 10 and Fig. 11.

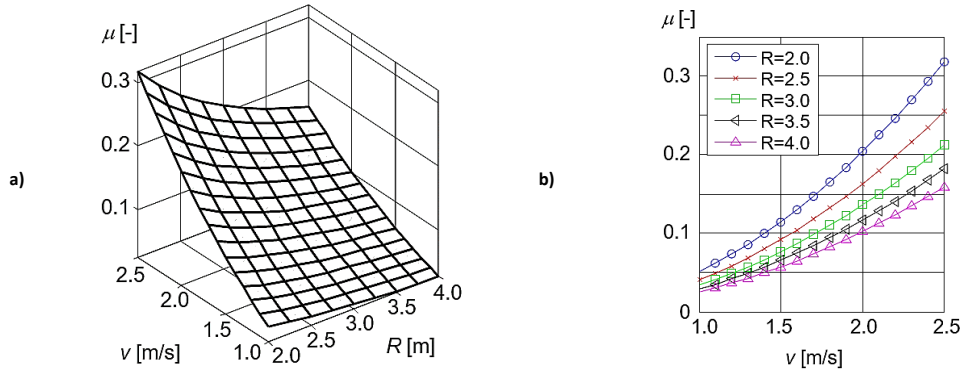

Fig. 10. Friction coefficient responsible for prevention of occurrence of motion of an object towards a tray on the curvatures of a track: a) in R and v function, b) in v function; $\alpha = 0^\circ$

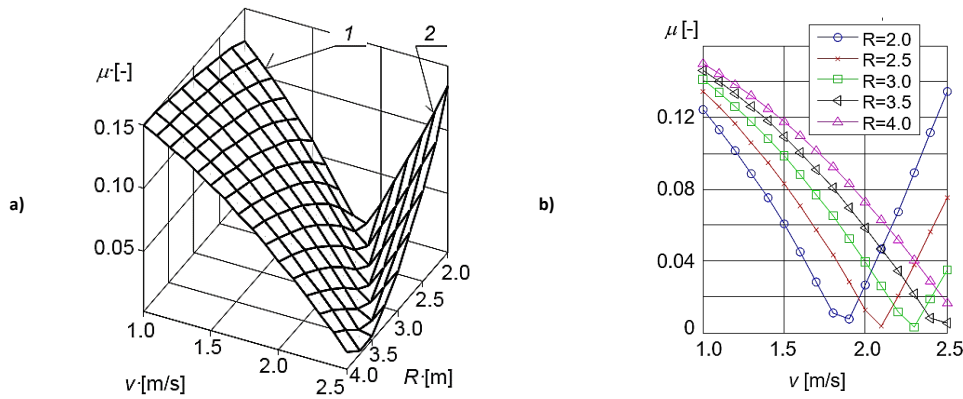

Fig. 11. Friction coefficient responsible for prevention of occurrence of motion of an object relative a tray on the curvatures of a track: a) in R and v function, b) in v function; $\alpha = 10^\circ$

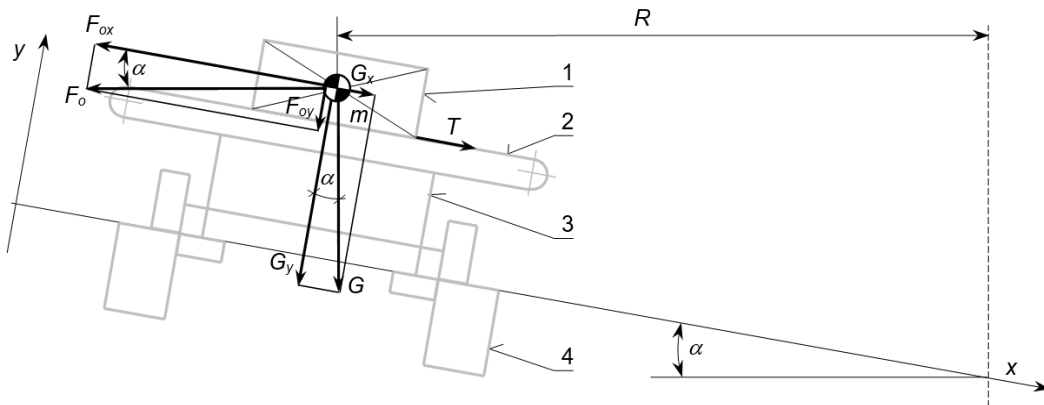

Fig. 12. A diagram of forces exerted on an object lying on a tray, moving on the arc of the track inclined towards the horizontal at an angle α : 1 – object, 2 – tray, 3 – trolley, 4 – track

Data were determined in a function of velocity v of the trays and radius R of the curvature of the track. In case of the tracks placed horizontally ($\alpha = 0^\circ$, Fig. 11), velocity $v = 2.5$ m/s and radius of the track $R = 2.5$ m, transported objects should have frictional properties $\mu > 0.25$. Inclination of the tracks by $\alpha = 10^\circ$ (Fig. 11) allows to transport much more slippery objects – $\mu > 0.15$. The graph from Fig. 11a consists of two parts: reference (1) refers to dominant impact of gravitational force during potential motion of an object towards a tray to the inside of the bend, reference (2) – dominant impact of centrifugal force, causing hypothetical skid of an object outside of the bend. Due to protection of an object against fall from a conveyor, surface of a graph marked by a reference (2) should be taken into account – an object shall not leave a tray if friction coefficient shall have value higher than the value determined by this surface.

2. THE SELECTION OF THE MAIN DRIVE UNITS OF A SORTER

DRIVING ROLL OF A BELT OF A TRANSVERSE TRAY

High efficiency of sorting devices forces also the need of application of high-efficiency infeed lines (2) – Fig. 3, and (4) – Fig. 13, putting the objects on

the belts of the trays, parallel to their edges (Fig. 13).

Initial location of an object (1) on the infeed conveyor (4) towards a tray (2) and their velocity should be selected so as to, as a result of the process of positioning, obtain, for example, central location of an object on a tray, parallel to this tray edges. While placing an object in a tray, velocities v_r and v_{inf} of motion of a conveyor of a tray and infeed conveyor of angular entrance have values related to transport velocity v of the trays, according to a diagram from Fig. 13:

$$v_r = v \tan \delta, \quad v_{inf} = \frac{v}{\cos} \quad (14)$$

The application of these relations causes that an object is placed on the trays, without skid. Such state lasts until the moment of getting location II (Fig. 13) by an object. Then, transverse conveyor of a tray moves with uniformly retarded motion, providing conditions of static friction between an object and tray. Therefore, while we know the length of the trajectory, we can accurately define the time of stopping the conveyor of a tray, in which object reaches selected location, for example, the centre K of a tray.

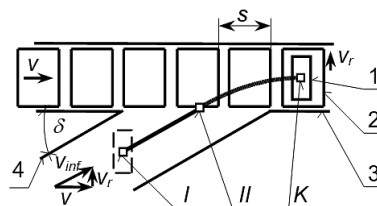

Fig. 13. A diagram of velocity of trays in the main track, infeed conveyor and belts of trays: 1 – object, 2 – tray, 3 – track, 4 – infeed line, I – initial location of an object and trays (the beginning of concurrent motion of belts of trays of constant velocity), II – location of an object at the moment of initiation of concurrent, retarded motion of belts of trays, K – the end of positioning process, s – distance between the fronts of trays

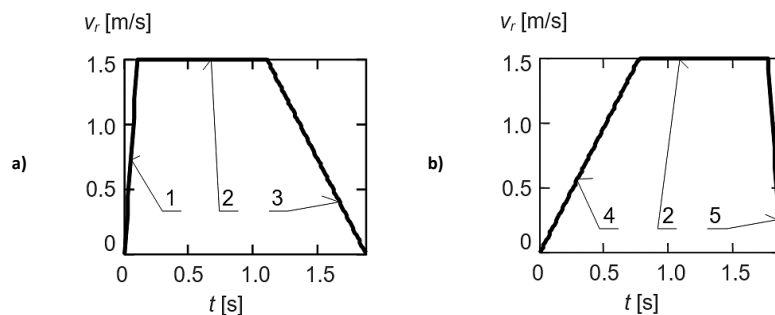

Fig. 14. A diagram of velocity v_r of transverse belts of the trays during: a) loading of an object to a tray, b) unloading of an object from a tray; 1 – starting of a belt without an object, 2 – uniform motion, 3 – stopping without skid of an object relative the belt, 4 – starting without skid of an object relative the belt, 5 – stopping the belt without an object

Cross-belt sorter – a model and analysis of selected mechanical loads

Assuming friction coefficient $\mu_1 = 0.2$ (Tab. 2) for the most slippery object and condition of avoiding its skid relative a tray, a diagram of velocity of starting and stopping the belt of a tray during loading and unloading was shown on Fig. 14. Not allowing for occurrence of skid of an object relative a tray results from the need to avoid unpredictable transient states of motion of an object, making its precise positioning more difficult

Required torque, power of a drive roll and efficiency of the trays are described by the relations:

$$M_r = m_p g (\mu_1 + \mu_2) r \quad (15)$$

$$P_r = v_r m_p g (\mu_1 + \mu_2) \quad (16)$$

$$W = \frac{3600v}{s} \quad (17)$$

The results of application of these relations were shown in Table 3. The parameters from Table 2 were used in calculations. Classic Coulomb model was applied to describe frictional properties.

LINEAR DRIVE OF TRANSLATIONAL MOTION OF TROLLEYS

The linear drives are used to set trolleys of a sorter in translational motion in a track. There are two solutions of drives (Fig. 15): friction and electromagnetic.

Friction drive is an older solution, in which application of frictional rolls affecting driving strips of trays (Fig. 15a) are applied. Nowadays, electromagnetic drives are applied more and more often (Fig. 15b). The advantage of electromagnetic drives is non-contact character of cooperation of an engine and trays and resulting minimization of noise and mechanical wear.

Required towing power of linear motors and their power can be determined according to the following relations:

$$F_t = n_t m_t g \mu_3 \quad (18)$$

$$P_t = v F_t \quad (19)$$

The results of calculations were presented in table 4. Data for these calculations were taken from Tables 1, 2 and 4.

CONCLUSIONS

An analysis of mechanical loads carried out for fundamental structural elements of a cross-belt sorter was presented in this article. The research included track and cooperating trolleys with the trays covered with transverse belt conveyors. Based on carried out analyses, it was found that within the range of velocity of transporting applied in high-efficiency warehouses, trolleys loaded with transported objects are not exposed to overturning in motion on the bends.

Table 2. The parameters of motion of a belt of a tray

Marking	Quantity	Value
v_r	velocity of a transverse belt	1.2 m/s i 1.5 m/s
r	radius of a drive roll	0.05 m
μ_1	coefficient of friction between tray belt and object	0.2
μ_2	coefficient of friction between belt and table of a tray	0.4
δ	angle between infeed conveyor and track	30°
g	gravitational acceleration	9.81 m/s ²
s	distance between the fronts of trays	0.6 m

Table 3. The results of calculations of a drive roll of a tray

v_r [m/s] velocity of a belt of a tray	v [m/s] velocity of trolleys	v_{inf} [m/s] infeed velocity	W [pcs/h] efficiency	M_r [Nm] torque	P_r [W] power
1.2	2.07	1,38	12 470.76	3,67	176.58
1.5	2.59	3,00	15 588.45	3,67	220.72

Table 4. The results of calculations of a linear drive

n_t [-] number of trolleys	v [m/s] velocity of trolleys	μ_3 [-] coefficient of rolling friction of trolleys in a track	$m_t = m + m_p$ [kg] mass of a trolley, tray and object	F_t [N] towing force	P_t [W] power
30	2,5	0.025	140	1030	2574

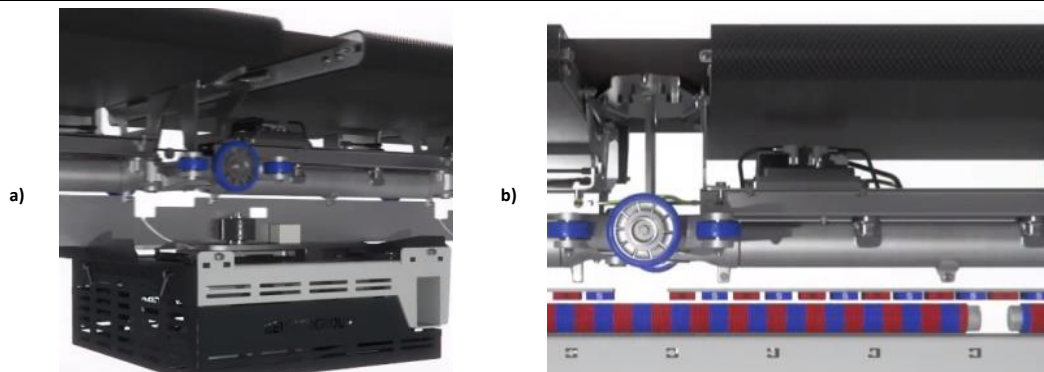

Fig. 15. The linear drives of the trolleys of a sorter [5]: a) friction, b) electromagnetic

Therefore, the tracks can be designed in horizontal position, without the need of application of inclinations. However, the application of inclinations of a track allows for more uniform load of external and internal tracks. Moreover, inclination of the tracks has positive impact on prevention of falling the slippery objects down from the trays. A fundamental assumption while placing objects on the sorter is fulfilment of condition of arising of static friction between the objects and bearing surfaces of conveyors. To meet this condition, it is necessary to apply close relation between velocities of translational motion of trays, belt of a transverse conveyor of a tray and infeed conveyor. In addition, the ramps of starting and stopping the transverse belt of a tray, in which static friction of transported object does not break should be applied. The course of the track of motion of an object under conditions of static friction is fully predictable, in contrast with kinetic friction, non-linear transient states generating. Due to the fact that the selection of the main operating parameters of the sorter requires the fulfilment of static friction conditions in the kinematic pair: the cross-belt of the tray – sorted object, the Coulomb friction model is a suitable description of the frictional properties. This model is one of the simplest models, which at the same time allows for unambiguous identification of the state of static friction.

The results of carried out analysis may be treated as recommendations at the stage of designing new sorters and during the use of existing solutions.

The research is co-financed by the European Regional Development Fund under NCBR POIR.04.01.04-00-0006/19 grant, "Cross-belt system for automated sorting of unit loads by a two-stage method", performed in 2019-2022.

SORTER TYPU CROSS-BELT – MODEL I ANALIZA WYBRANYCH OBCIĄŻEŃ MECHANICZNYCH

W artykule przedstawiono wyniki badań numerycznych eksploatacyjnych obciążeń mechanicznych, wykonanych dla głównych elementów konstrukcyjnych sortera cross-belt: torów jezdnych i wózków z tackami. Celem badań jest pozyskanie danych wymaganych na etapie projektowania nowych rozwiązań sorterów. Nowością jest model analityczny pozwalający określić wpływ prędkości ruchu wózków, właściwości ciernych i ciężaru sortowanych obiektów na siły oddziaływania wózków na tor jezdny, wydajność sortowania i zapotrzebowanie mocy układów napędowych.

Słowa kluczowe: proces sortowania, tacka, wózek, ładunek jednostkowy, centrum logistyczne

REFERENCES

- [1] Böhringer K.F., Donald B.R., Kavraki L.E. (2000) "Part orientation with one or two stable equilibria using programmable force fields", IEEE Transactions on Robotics and Automation. Vol 16. pp 157-170. DOI: 10.1109/70.843172
- [2] Akella S., Huang W.H., Lynch K.M. Mason, M.T. (2000) "Parts feeding on a conveyor with a one joint robot", Algorithmica, Springer - Verlag, Vol 26. pp 313-344. doi.org/10.1007/s004539910016
- [3] Piątkowski T. NCBR grant POIR.04.01.04-00-0006/19, "Cross-belt system for automated sorting of unit loads by a two-stage method", performed in 2019-2021, under Sub-measure 4.1.4 of the PO IR "Application Projects".
- [4] Piątkowski T., Wolski M. (2021) "Model of positioning objects by the system of oblique friction force fields on horizontal and vertically offset planes", Mechanism and Machine Theory, Vol 156. doi.org/10.1016/j.mechmachtheory.2020.104155

Cross-belt sorter – a model and analysis of selected mechanical loads

- [5] New Generation of High-Performance Sorting: The BG Sorter, Commercial material published by BeumerGroup. www.youtube.com/watch?v=fbmKbb8W_Xg (accessed date: 22.07.2019)
- [6] Crossbelt Sorter, Commercial folder published by Dematic, www.dematic.com/pl-pl/supply-chain-solutions/by-technology/sortation-systems/circular-sorters/crossbelt-sorter/ (accessed date: 22.07.2019)
- [7] Pennestri E., Rossi V., P. Salvini, Valentini P.P. "Review and comparison of dry friction force models", *Nonlinear Dynamics*, 83. 1785-1801. doi.org/10.1007/s11071-015-2485-3
- [8] Marques F., Flores P., Lankarani H.M. (2016) "On the frictional contacts in multibody system dynamics", *Multibody Dynamics. Computational Methods in Applied Sciences*. Vol 42. pp 67-91. doi.org/10.1007/978-3-319-30614-8_4
- [9] Marques F., Flores P., Claro J.C.P., Lankarani H.M. (2019) "Modeling and analysis of friction including rolling effects in multibody dynamics", *Multibody System Dynamics*. Vol 45. pp 223-244. doi.org/10.1007/s11044-018-09640-6
- [10] Marques F., Flores P., Claro J.C.P., Lankarani H. M. (2016) "A survey and comparison of several friction force models for dynamic analysis of multibody mechanical systems", *Nonlinear Dynamics*, Vol 86, pp 1407-1443. doi.org/10.1007/s11071-016-2999-3
- [11] Chen S., Zhang Z. (2020) "Modification of friction for straightforward implementation of friction law", *Multibody System Dynamics*. Vol 48. pp 239-257. doi.org/10.1007/s11044-019-09694-0
- [12] Dahl P.R. (1968) A solid friction model. Technical Report. The Aerospace Corporation, El Segundo, California.
- [13] Canudas de Wit C., Olsson H., Åström K.J., Lischinsky P. (1995) "A new model for control of systems with friction", *IEEE Transactions on Automatic Control*. 40. pp 419-425. doi.org/10.1109/9.376053
- [14] Swevers J., Al-Bender F., Ganseman C.G., Projogo T. (2000) "An integrated friction model structure with improved presliding behavior for accurate friction compensation", *IEEE Transactions on Automatic Control*. Vol 45. pp 675-686. doi.org/10.1109/9.847103
- [15] Dupont P., Armstrong B., Hayward V. (2000) "Elasto-plastic friction model: contact compliance and stiction", *Proceedings of the 2000 American Control Conference*. Vol 2. pp 1072-1077. doi.org/10.1109/ACC.2000.876665
- [16] Shi J., Woodruff J. Z., Umbanhowar B., Lynch K. M. (2017) "Dynamic in-hand sliding manipulation", *IEEE Transactions on Robotics*. Vol 33. pp 778- 795. doi.org/10.1109/TRO.2017.2693391
- [17] Flores P., MacHado M., Silva M.T., Martins J.M. (2011) "On the continuous contact force models for soft materials in multibody dynamics", *Multibody Syst. Dyn*. Vol 25. pp 357-75. doi.org/10.1007/s11044-010-9237-4